

# Service Bulletin SB-65

V 1.1

## Electrical Installation ID - 2800

### Table of Contents

- Overview of Service Bulletins for Integrated Drives (ID) .....2**
- 1 Overview Driver Unit ID – 2800 .....3**
- 2 Stepping driver controller Interface for EXPERT .....3**
  - 2.1 Communication Interfaces .....3
  - 2.2 Block-diagram of the stepping motor driver .....3
- 3 Controller Board ID Connections for ID - 2800 .....4**
  - 3.1 Operating ratings for ID-2800 .....6

## Overview of Service Bulletins for Integrated Drives (ID)

- SB-60** Overview of Integrated Drives
- General product description
  - Drive unit product lines and related capacitor series
  - Function levels and configurations
  - Description of module components
  - Technical specifications
  - Overview of the product range
  - Type designation
- SB-61** Drive Unit
- Drive unit product lines
  - Description of the drive unit components
- SB-62** Introduction to Stepping Motors
- Principal function of stepper motors
  - Control system of the drive unit
- SB-63** Electrical Installation ID-400
- Stepping driver control signals and connections for EXPERT ID
- SB-64** Electrical Installation ID-1200
- Stepping driver control signals and connections for EXPERT ID
- SB-65** Electrical Installation ID-2800
- Stepping driver control signals and connections for EXPERT ID
- SB-66** Electrical Installation ID-5400
- Stepping driver control signals and connections for EXPERT ID
- SB-67** Step/Direction; Clockwise / Counter clockwise (CW/CCW) Interface
- Stepping driver signals
  - Stepping driver timing diagram
- SB-68** Software Protocol Interface RS-232
- Specification of the interface
  - Frame structure
  - Communication protocol between the ID and the host system
- SB-69** Software Protocol Interface RS-485
- Specification
  - Frame structure
  - Communication protocol between the ID and the host system
- SB-70** Software Protocol Interface I<sup>2</sup>C
- Available soon
- SB-71** Software Protocol Interface SPI
- Available soon
- SB-72** Safety Aspects of Integrated Drives
- Capacitor
  - Electrical Insulation between ID and Capacitor
- SB-73** Test results for Integrated Drives
- Tests of components
  - Life time tests

**DATA SHEETS** are available for each Integrated Drive

# 1 Overview Driver Unit ID – 2800

Picture 1 shows and explain the components of the ID – 2800.

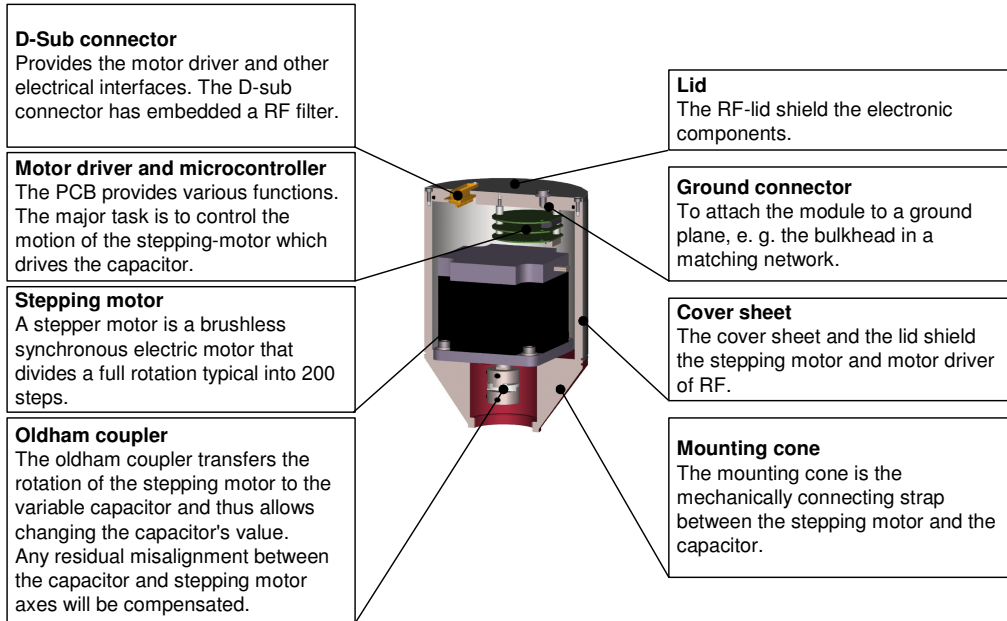

Fig. 1: Components of the driver unit ID - 2800

## 2 Stepping driver controller Interface for EXPERT

### 2.1 Communication Interfaces

The communication interface is that interface between the controller unit (e.g. PC) and the driver board. Specifications of the COMET proprietary communication protocols are available for the RS-232 and RS-485 interfaces.

### 2.2 Block-diagram of the stepping motor driver

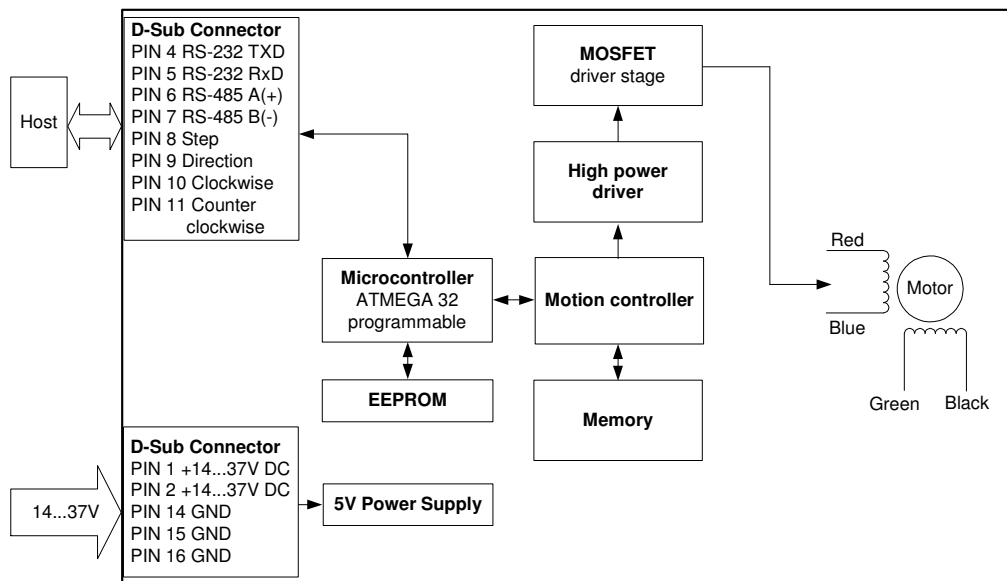

Fig. 2: Terminology of driver and motor control signals

### 3 Controller Board ID Connections for ID - 2800

Power is provided to the PCB through pins VCC and GND. To ensure a proper flow of current, all pins of the Power Connector must be used. The pin connections below depend on the interface configuration used.

Pin	Function
1	+ 14 ... 37 V DC (VCC)
2	+ 14 ... 37 V DC (VCC)
3	-
4	TxD (RS-232)
5	RxD (RS-232)
6	A (+) (RS-485)
7	B (-) (RS-485)
8	Step
9	Direction
10	Clockwise
11	Counter clockwise
12	--
13	--
14	GND
15	GND
16	GND
17	Left limit switch
18	Right limit switch
19	General purpose output
20	General purpose input
21	+ 5 V DC output (max. 20 mA)
22	I <sup>2</sup> C
23	I <sup>2</sup> C
24	SPI
25	SPI

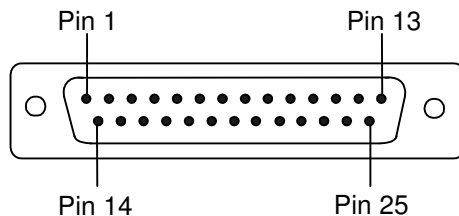

Fig. 3: Pin layout of connector D-Sub-25 for ID - 2800

The ID-2800 is equipped with a linear voltage regulator that generates the 5V supply voltage for the digital components of the module from the motor power supply. So only one supply voltage is needed for the module. The power supply voltage can be +14...+37 V DC. A higher voltage gives higher motor dynamics. Please note that there is no protection against reverse polarity or too high voltage. The power supply should be designed in a way, that it supplies the nominal motor voltage at the desired maximum motor power. In no case shall the supply value exceed the upper / lower voltage limit. To ensure reliable operation of the unit, the power supply has to have a sufficient output capacitor and the supply cables should have a low resistance, so that the chopper operation does not lead to an increased power supply ripple directly at the unit. Power supply ripple due to the chopper operation should be kept at a maximum of a few hundred millivolts. This also is important in order to make the users application compatible to any applicable EMC guidelines.

Therefore we recommend to:

- keep power supply cables as short as possible
- use large diameter for power supply cables
- If the distance to the power supply is large (i.e. more than 2 - 6m), use a robust 470µF or larger additional filtering capacitor located near to the motor driver unit.

The limit switch inputs are equipped with internal pull-up resistors, so they have to be connected to GND via normally closed switches. They are used as an absolute position reference for homing and to set a hardware limit for the motion range<sup>1</sup>. The general purpose output is an open collector output for a maximum current of 100mA. A freewheeling diode is also included so that e.g. a relay or a coil can be connected directly. Please note that the freewheeling diode is connected to the supply voltage and not to +5V, so when using e.g. a relay that is connected to +5V a freewheeling diode must be connected externally. The general purpose input is used as a digital TTL input. By connecting pin 20 to a high voltage state (3.5 – 5.5Volts) the ID will do a reference drive.

### Connecting the electrical interfaces

This connector provides the access to and from the PCB via serial interfaces, i. e. RS-232.





Pin	Interface					
	EXPERT-1	EXPERT-2	EXPERT-3	EXPERT-3	EXPERT-4	EXPERT-5
	RS-232	RS-485	Step / Direction	CW / CCW	I <sup>2</sup> C	SPI
4	TxD	--	--	--	--	--
5	RxD	--	--	--	--	--
6	--	A (+)	--	--	--	--
7	--	B (-)	--	--	--	--
8	--	--	Step 	--	--	--
9	--	--	Dir. 	--	--	--
10	--	--	--	CW 	--	--
11	--	--	--	CCW 	--	--
22	--	--	--	--	SDA	Serial data in
23	--	--	--	--	SCL	Serial data out
24	--	--	--	--	--	Chip select
25	--	--	--	--	--	Serial clock

Fig. 4: Electrical interface connections

<sup>1</sup> This function is only available on request

### 3.1 Operating ratings ID - 2800

Symbol	Parameter	Min	Typical	Max	Unit
$V_S$	Power supply voltage	14	15...36	37	V
$I_{COIL}$	Motor coil current for sine wave peak (chopper regulated, adjustable via software)	0	2.8...7	7.1	A
$I_{MC}$	Continuous motor current (RMS)	0	2...5	5.0	A
$I_S$	Power supply current		2...3	7.1	A
$U_{+5V}$	+5V output (max. 20mA)	4.8	5.0	5.2	V

Fig. 5: Operation ratings for the ID - 2800